

# CCPD-024 5×7mm SMD LVPECL Clock Oscillator

**CCPD-024 Model**  
5×7 mm SMD, 2.5V, LVPECL



**Model CCPD-024 is a 162.000 MHz to 250.000 MHz LVPECL Clock Oscillator operating at 2.5 Volts. The oscillator utilizes a High Q crystal design providing very low Jitter and Phase Noise. No Sub-Harmonics are present in the Output Signal.**



**5×7mm SMD**

## **Applications:**

**Digital Video  
SONET/SDH/DWDM  
Storage Area Networks  
Broadband Access  
Ethernet, Gigabit Ethernet**

Rev: H
Date: 19-Jan-2017
Page 1 of 3

# CCPD-024 5×7mm SMD LVPECL Clock Oscillator



## CCPD-024 Model

5×7 mm SMD, 2.5V, LVPECL

<b>Frequency Range:</b>	162.000 MHz to 250.000 MHz
<b>Frequency Stability Options(ppm):</b>	±20, ±25, ±50, ±100
<b>Temperature Range:</b>	(standard) 0°C to +70°C
	(Option M) -20°C to +70°C
	(Option X) -40°C to +85°C
<b>Storage:</b>	-45°C to 90°C
<b>Input Voltage:</b>	2.5V ±0.125V
<b>Input Current:</b>	55mA Typical, 88mA Max
<b>Output:</b>	Differential LVPECL
<b>Symmetry:</b>	45/55% Max @ zero crossing point
<b>Rise/Fall Time:</b>	1nsec Max (20% to 80%)
<b>Logic:</b>	Terminated to Vdd-2V into 50 Ω
<b>Temp. 0°C to 85°C</b>	“0”=0.690 Min, 1.095 Max “1”=1.475 Min, 1.760 Max
<b>Temp. -40°C to 0°C</b>	“0”=0.670 Min, 1.195 Max “1”=1.415 Min, 1.620 Max
<b>Disable Time:</b>	200nSec Max
<b>Enable Time:</b>	1mSec Typical, 2mSec Max
<b>Phase Jitter: 12kHz~80MHz</b>	0.5psec Typical, 1psec RMS Max
<b>Phase Noise: (See Plot Below)</b>	
<b>Sub-harmonics:</b>	None
<b>Aging:</b>	<3ppm 1 <sup>st</sup> year, <1ppm every year thereafter

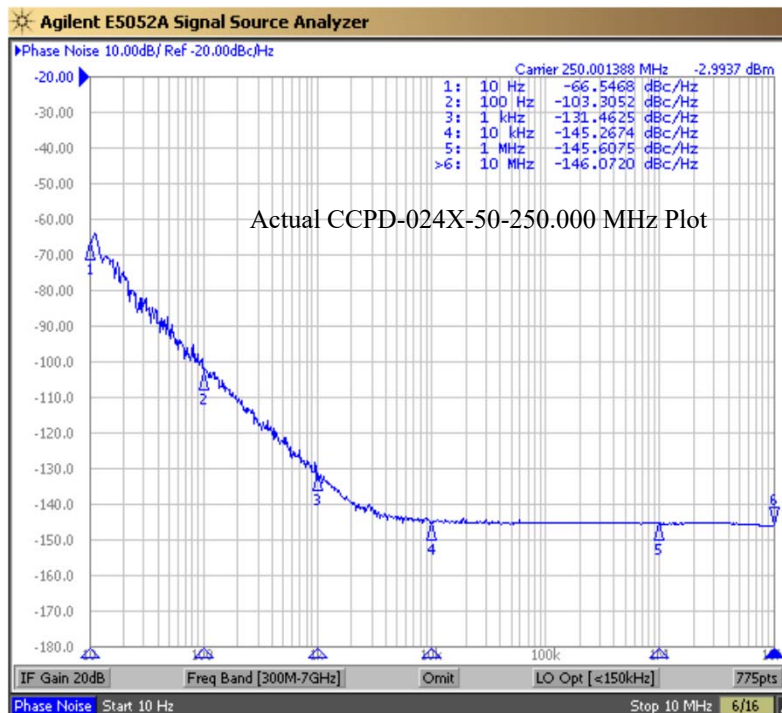

Rev: H  
Date: 19-Jan-2017  
Page 2 of 3

Specifications subject to change without notice.

**CCPD-024 Model**  
5×7 mm SMD, 2.5V, LVPECL



Crystek Part Number Guide																
<b>CCPD - 024 X - 25 - 250.000</b>																
#1	#2	#3	#4	#5												
#1 Crystek LVPECL Osc. #2 Model 024 #3 Temp Range: Blank = 0/70°C, M = -20/70°C, X = -40/85°C #4 Stability: (see Table 1) #5 Frequency in MHz: 3 or 6 decimal places																
Example: CCPD-024X-25-250.000 2.5V, -40/85°C, ±25ppm, 250.000 MHz																
			<table border="1"> <thead> <tr> <th colspan="2">Stability Indicator</th> </tr> </thead> <tbody> <tr> <td>Blank</td> <td>± 100ppm</td> </tr> <tr> <td>50</td> <td>± 50ppm</td> </tr> <tr> <td>25</td> <td>± 25ppm</td> </tr> <tr> <td>20*</td> <td>± 20ppm</td> </tr> <tr> <td colspan="2">*not available in -40/85</td> </tr> </tbody> </table>		Stability Indicator		Blank	± 100ppm	50	± 50ppm	25	± 25ppm	20*	± 20ppm	*not available in -40/85	
Stability Indicator																
Blank	± 100ppm															
50	± 50ppm															
25	± 25ppm															
20*	± 20ppm															
*not available in -40/85																
Table 1																

Mechanical:	
Shock:	MIL-STD-883, Method 2002, Condition B
Solderability:	MIL-STD-883, Method 2003
Vibration:	MIL-STD-883, Method 2007, Condition A
Solvent Resistance:	MIL-STD-202, Method 215
Resistance to Soldering Heat:	MIL-STD-202, Method 210, Condition I or J
Environmental:	
Thermal Shock:	MIL-STD-883, Method 1011, Condition A
Moisture Resistance:	MIL-STD-883, Method 1004

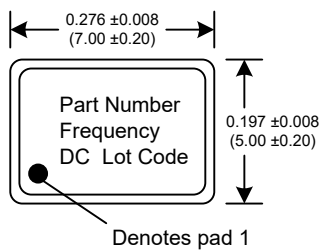
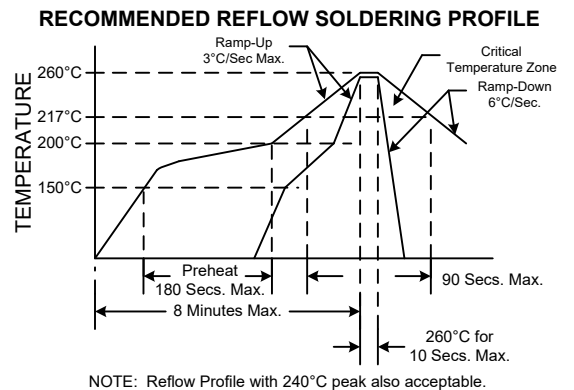

Dimensions inches (mm)  
All dimensions are Max unless otherwise specified.

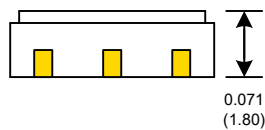

Enable/Disable Function	
Function pin 1	Output pin
Open or N/C	Active
"1" level 0.7×V <sub>dd</sub> Min	Active
"0" level 0.3×V <sub>dd</sub> Max	High Z

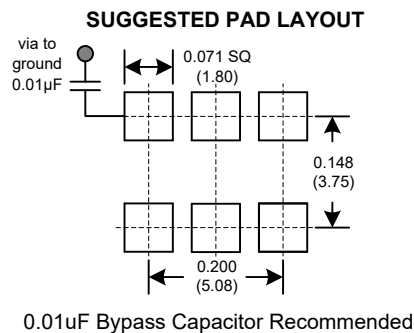
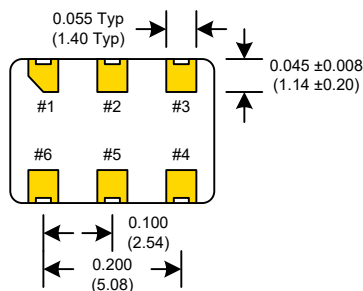

PIN	Connection
1	Enable/Disable
2	N/C
3	GND
4	Output
5	Comp Output
6	V <sub>cc</sub>

Rev: H  
Date: 19-Jan-2017  
Page 3 of 3