

Absolute Pulling Range (APR)

A VCXO is a crystal oscillator where its output frequency changes in direct proportion to the application of an input control voltage. There are many names given or assigned to this output frequency being changed with the control voltage, which can be confusing. All the following terms are used and basically mean the same thing:

Deviation

Frequency Deviation

Modulation

Frequency Modulation

Pulling

Pull

Pullability

Absolute Pulling Range (APR)

Warping

You will find these terms and others in different VCXO manufacturer data sheets. MIL-0-55310 uses the term “Deviation” but most suppliers like to use “Pullability” in their data sheet.

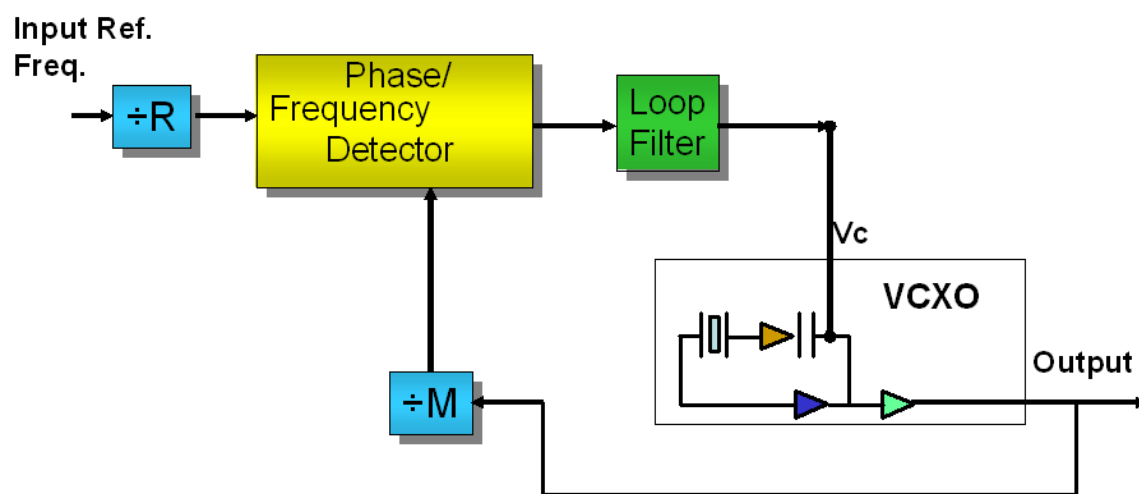

A typical PLL application using a VCXO is depicted in Figure 1. In this application the designer must make sure the PLL remains locked under all conditions including the life time of the product.

Absolute Pulling Range (APR) has become a very common way to specify a VCXO with simply one parameter which will guarantee the PLL remains locked under all conditions.

A VCXO has its own errors that if not accounted for can lead to not having enough frequency pulling range under certain conditions. These conditions can include:

- 1) Frequency vs. temperature
- 2) Aging vs. time
- 3) Center frequency calibration
- 4) Load and Supply change variation

The minimum pulling range of a VCXO is determined by:

Minimum VCXO Pull = Total VCXO errors + APR Desired

How does one determine what a APR is desired? The APR desired is a direct function of the overall frequency accuracy of the input reference in Figure 1. Hence if the input reference frequency is +/- 20ppm (overall), then the APR required is +/-20ppm minimum. In effect, the APR number is the tracking range of the PLL in ppm.

The VCXO manufacturer will determine the minimum pull required for a +/-50ppm APR unit as shown in the example below:

ABSOLUTE PULL RANGE (APR)

TEMPERATURE: +25 PPM

LOAD: +2 PPM

SUPPLY: +2 PPM

CALIBRATION: +10 PPM

AGING: +10 PPM

TOTAL ERROR = +49 PPM ← WORST CASE ERROR

MINIMUM PULL RANGE FOR THE VCXO IS :

TOTAL ERROR + APR DESIRED

**EXAMPLE: FOR +/- 50PPM APR VCXO WITH ABOVE
ERROR**

49 PPM + 50 PPM = 99 PPM

**THEREFORE, THE VCXO MUST BE RATED FOR +/- 100
PPM MIN FREQUENCY PULL OVER CONTROL
VOLTAGE RANGE**